

**60V N-Ch Power MOSFET**
**Feature**

- ◇ High Speed Power Switching, Logic Level
- ◇ Enhanced Avalanche Ruggedness
- ◇ 100% UIS Tested, 100% Rg Tested
- ◇ Lead Free, Halogen Free

$V_{DS}$		60	V
$R_{DS(on),typ}$	$V_{GS}=10V$	6.7	m $\Omega$
$R_{DS(on),typ}$	$V_{GS}=4.5V$	9.5	m $\Omega$
$I_D$ (Silicon Limited)		44.6	A
$I_D$ (Package Limited)		40	A

**Application**

- ◇ Hard Switching and High Speed Circuit
- ◇ DC/DC in Telecoms and Industrial

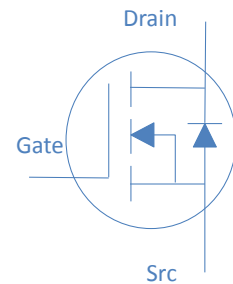
**DFN3.3x3.3**

Part Number	Package	Marking
HGM079N06SL	DFN 3.3*3.3	GM079N06L

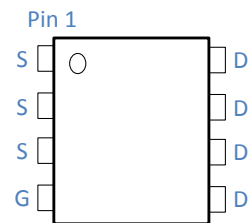
**Absolute Maximum Ratings at  $T_j=25^{\circ}C$  (unless otherwise specified)**

Parameter	Symbol	Conditions	Value	Unit
Continuous Drain Current (Silicon Limited)	$I_D$	$T_C=25^{\circ}C$	44.6	A
		$T_C=100^{\circ}C$	28	
Continuous Drain Current (Package Limited)		$T_C=25^{\circ}C$	40	A
Drain to Source Voltage	$V_{DS}$	-	60	V
Gate to Source Voltage	$V_{GS}$	-	$\pm 20$	V
Pulsed Drain Current	$I_{DM}$	-	270	A
Avalanche Energy, Single Pulse	$E_{AS}$	$L=0.3mH, T_C=25^{\circ}C$	60	mJ
Power Dissipation	$P_D$	$T_C=25^{\circ}C$	30	W
Operating and Storage Temperature	$T_J, T_{stg}$	-	-55 to 150	$^{\circ}C$

**Absolute Maximum Ratings**

Parameter	Symbol	Max	Unit
Thermal Resistance Junction-Ambient	$R_{\theta JA}$	50	$^{\circ}C/W$
Thermal Resistance Junction-Case	$R_{\theta JC}$	4.1	$^{\circ}C/W$

**Electrical Characteristics at  $T_J=25^{\circ}\text{C}$  (unless otherwise specified)**
**Static Characteristics**

Parameter	Symbol	Conditions	Value			Unit
			min	typ	max	
Drain to Source Breakdown Voltage	$V_{(BR)DSS}$	$V_{GS}=0V, I_D=250\mu A$	60	-	-	V
Gate Threshold Voltage	$V_{GS(th)}$	$V_{GS}=V_{DS}, I_D=250\mu A$	1.0	1.8	2.4	
Zero Gate Voltage Drain Current	$I_{DSS}$	$V_{GS}=0V, V_{DS}=60V, T_J=25^{\circ}\text{C}$	-	-	1	$\mu A$
		$V_{GS}=0V, V_{DS}=60V, T_J=100^{\circ}\text{C}$	-	-	100	
Gate to Source Leakage Current	$I_{GSS}$	$V_{GS}=\pm 20V, V_{DS}=0V$	-	-	$\pm 100$	nA
Drain to Source on Resistance	$R_{DS(on)}$	$V_{GS}=10V, I_D=20A$	-	6.7	7.9	m $\Omega$
		$V_{GS}=4.5V, I_D=16A$	-	9.5	11.8	
Transconductance	$g_{fs}$	$V_{DS}=5V, I_D=20A$	-	26	-	S
Gate Resistance	$R_G$	$V_{GS}=0V, V_{DS}$ Open, $f=1\text{MHz}$	-	1.5	-	$\Omega$

**Dynamic Characteristics**

Input Capacitance	$C_{iss}$	$V_{GS}=0V, V_{DS}=30V, f=1\text{MHz}$	-	1620	-	pF
Output Capacitance	$C_{oss}$		-	415	-	
Reverse Transfer Capacitance	$C_{rss}$		-	3	-	
Total Gate Charge	$Q_g(10V)$	$V_{DD}=30V, I_D=20A, V_{GS}=10V$	-	24	-	nC
	$Q_g(4.5V)$		-	12	-	
Gate to Source Charge	$Q_{gs}$		-	5.0	-	
Gate to Drain (Miller) Charge	$Q_{gd}$		-	3.0	-	
Turn on Delay Time	$t_{d(on)}$		-	9	-	
Rise time	$t_r$	$V_{DD}=30V, I_D=20A, V_{GS}=10V,$	-	4	-	
Turn off Delay Time	$t_{d(off)}$	$R_G=10\Omega,$	-	29	-	
Fall Time	$t_f$		-	4	-	

**Reverse Diode Characteristics**

Diode Forward Voltage	$V_{SD}$	$V_{GS}=0V, I_F=20A$	-	0.9	1.2	V
Reverse Recovery Time	$t_{rr}$	$V_R=30V, I_F=20A, d_{IF/dt}=300A/\mu s$	-	30	-	ns
Reverse Recovery Charge	$Q_{rr}$		-	43	-	nC

Fig 1. Typical Output Characteristics

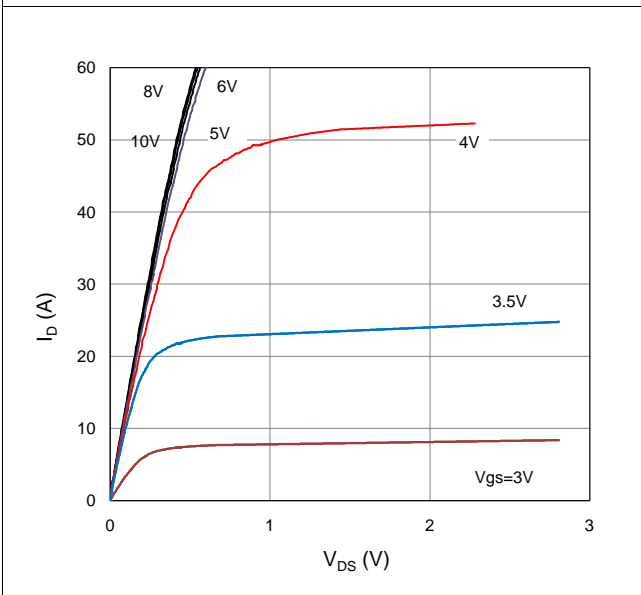

Figure 2. On-Resistance vs. Gate-Source Voltage

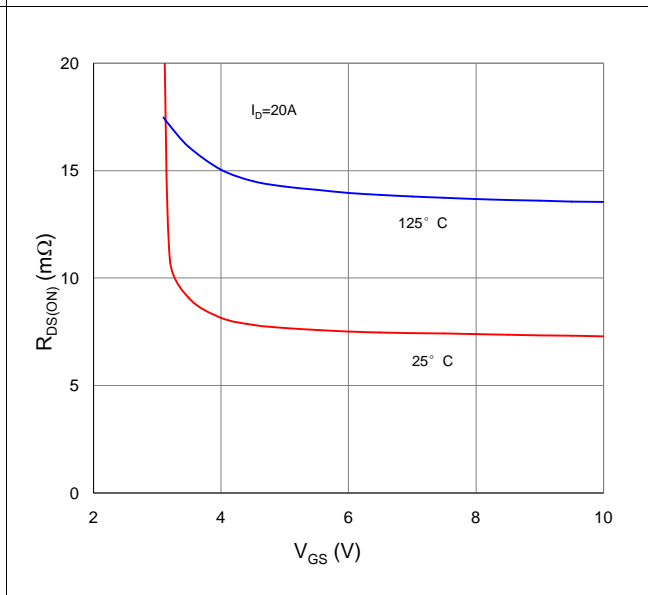

Figure 3. On-Resistance vs. Drain Current and Gate Voltage

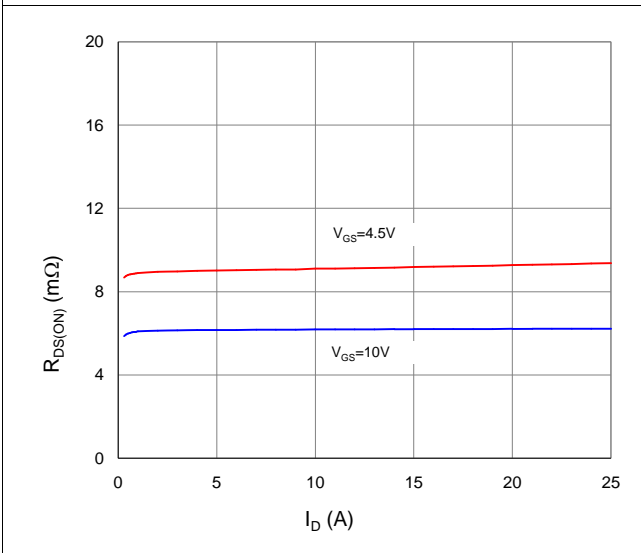

Figure 4. Normalized On-Resistance vs. Junction Temperature

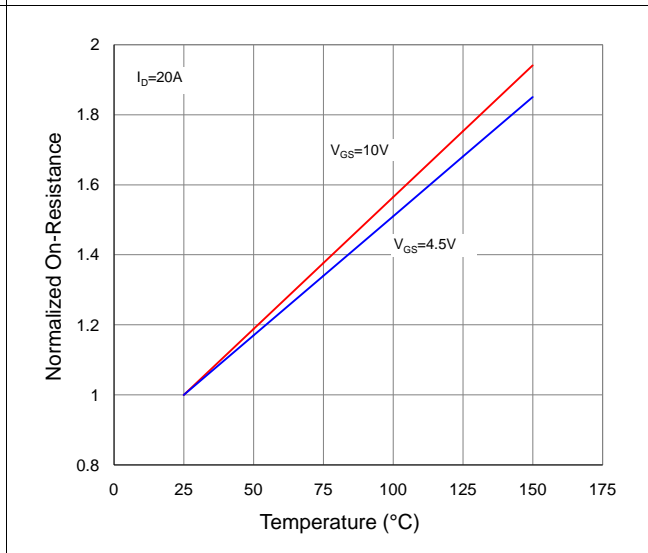

Figure 5. Typical Transfer Characteristics

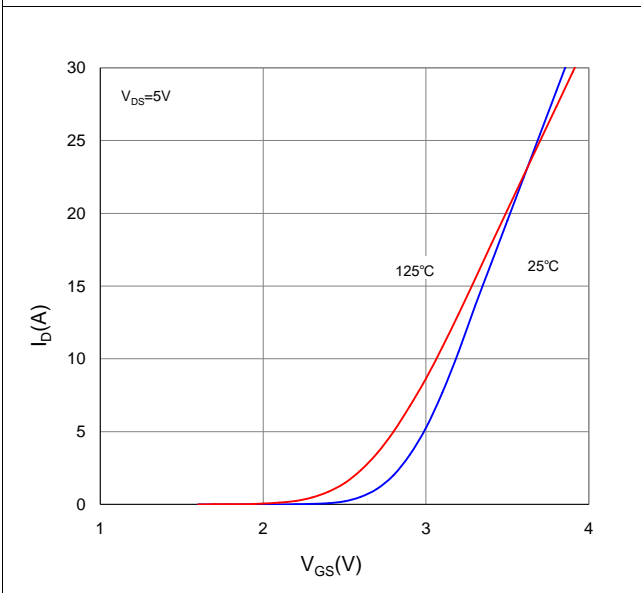

Figure 6. Typical Source-Drain Diode Forward Voltage

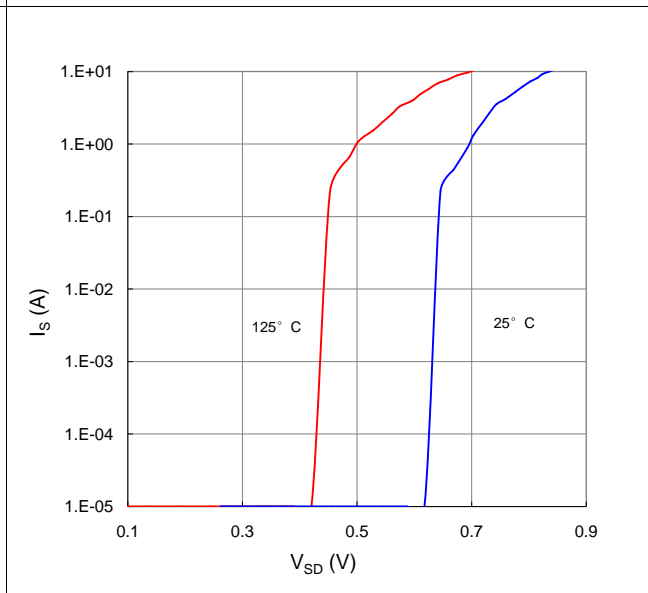

Figure 7. Typical Gate-Charge vs. Gate-to-Source Voltage

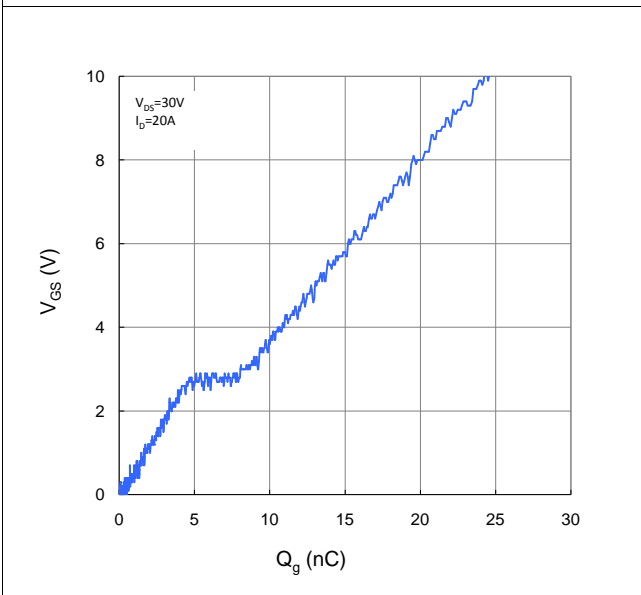

Figure 8. Typical Capacitance vs. Drain-to-Source Voltage

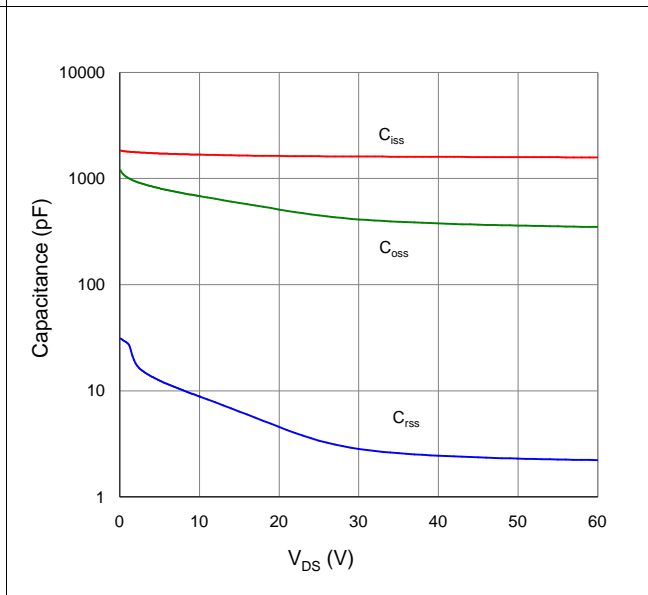

Figure 9. Maximum Safe Operating Area

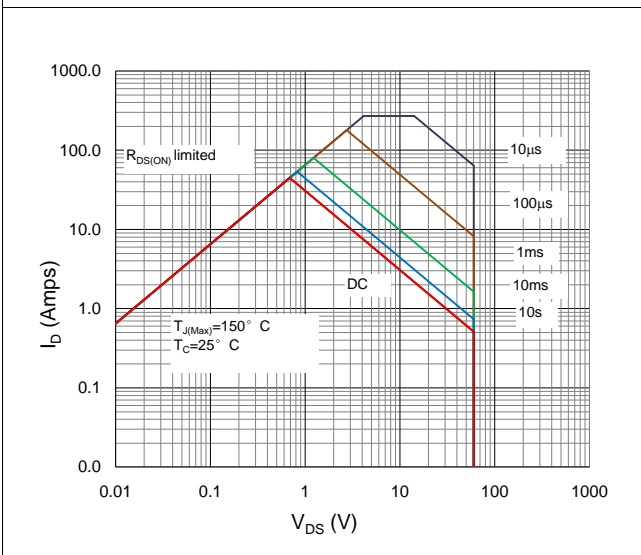

Figure 10. Maximum Drain Current vs. Case Temperature

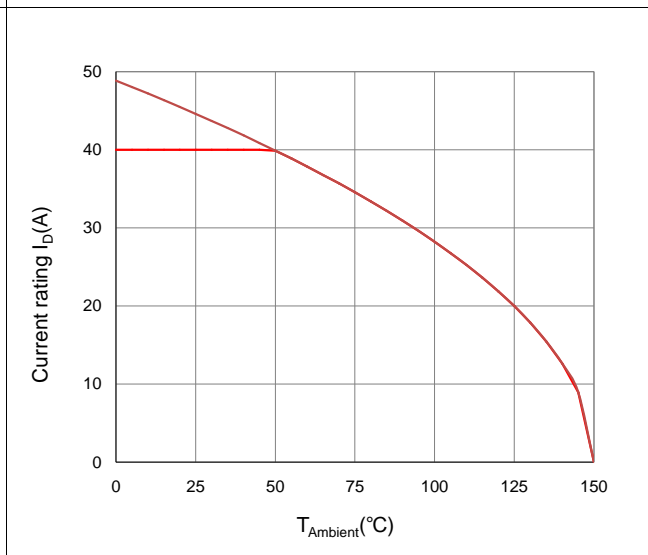
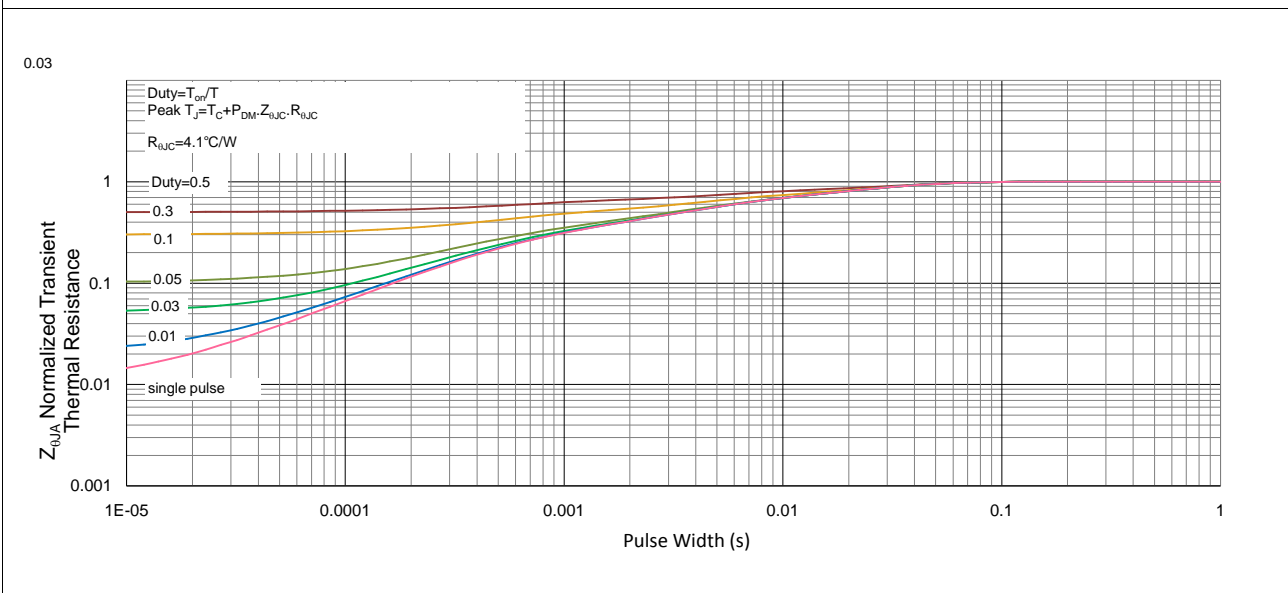
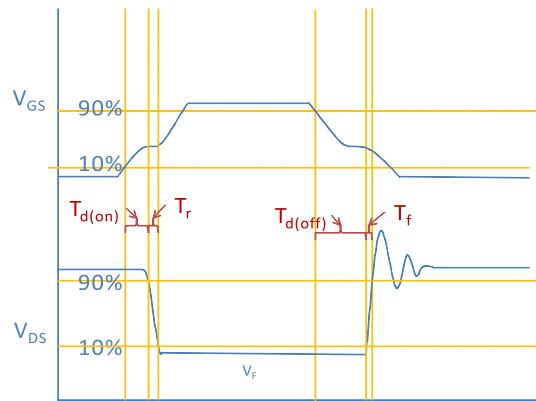
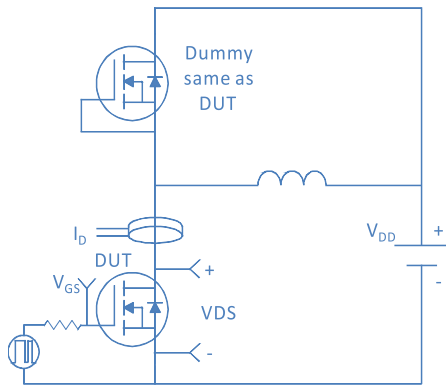

Figure 11. Normalized Maximum Transient Thermal Impedance, Junction-to-Ambient



Inductive switching Test



Gate Charge Test

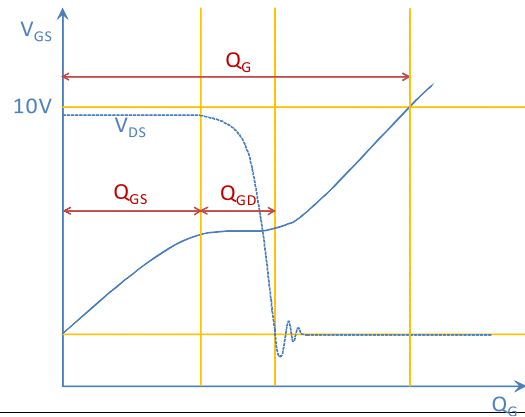
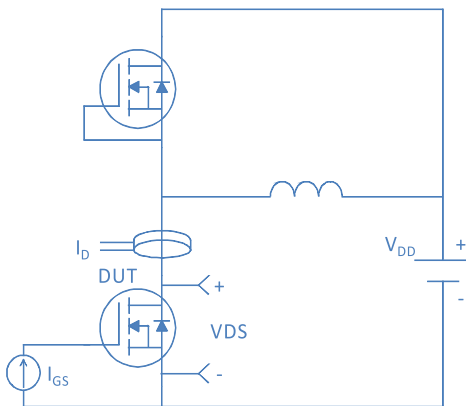

Uclamped Inductive Switching (UIS) Test

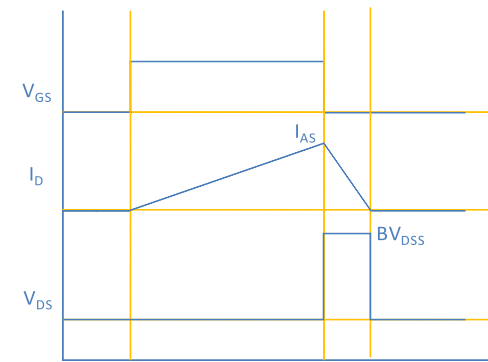
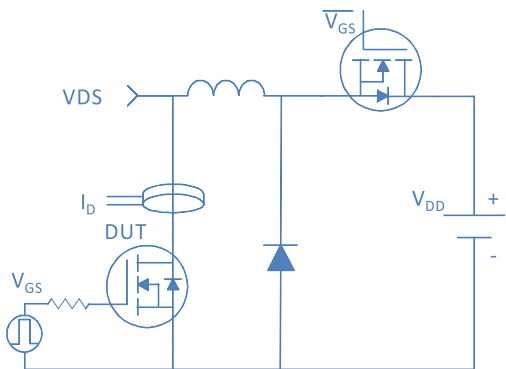

Diode Recovery Test

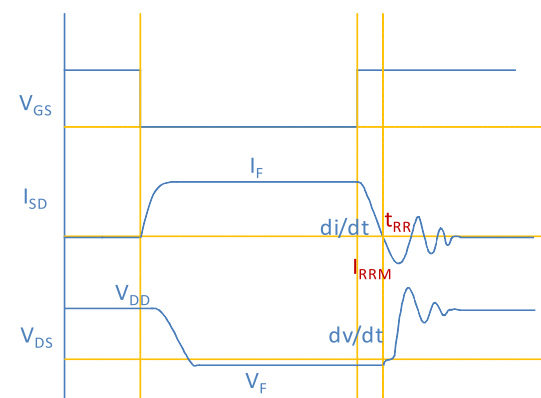
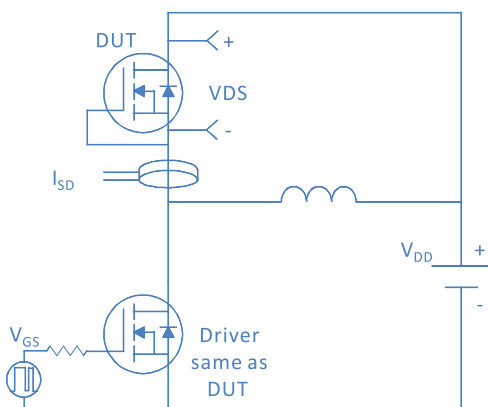

Package Outline

DFN3.3\*3.3\_P, 8 Leads

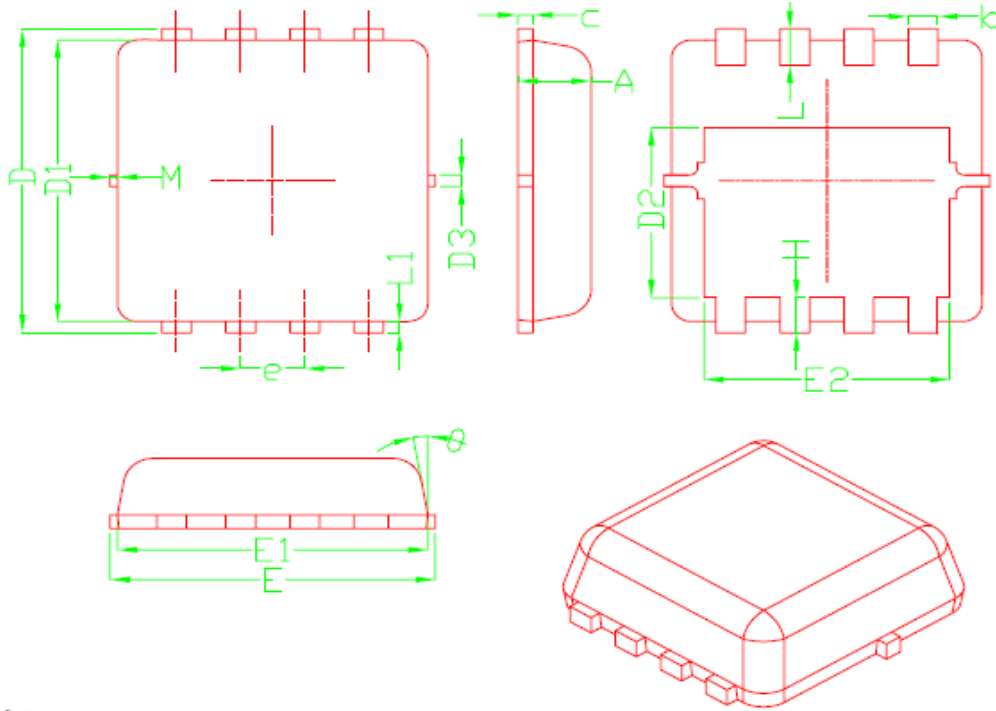

SYMBOL	DIMENSIONAL REQMTS		
	MIN	NOM	MAX
A	0.70	0.75	0.80
b	0.25	0.30	0.35
c	0.10	0.15	0.25
D	3.25	3.35	3.45
D1	3.00	3.10	3.20
D2	1.78	1.88	1.98
D3	---	0.13	---
E	3.20	3.30	3.40
E1	3.00	3.15	3.20
E2	2.39	2.49	2.59
e	0.65BSC		
H	0.30	0.39	0.50
L	0.30	0.40	0.50
L1	---	0.13	---
θ	---	10°	12°
M	*	*	0.15
* Not specified			